

THE GRAPH

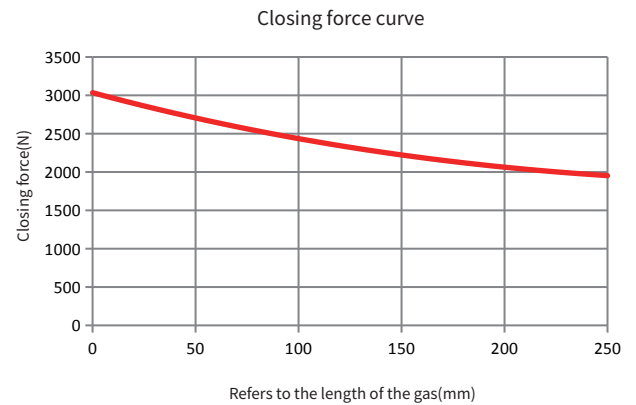
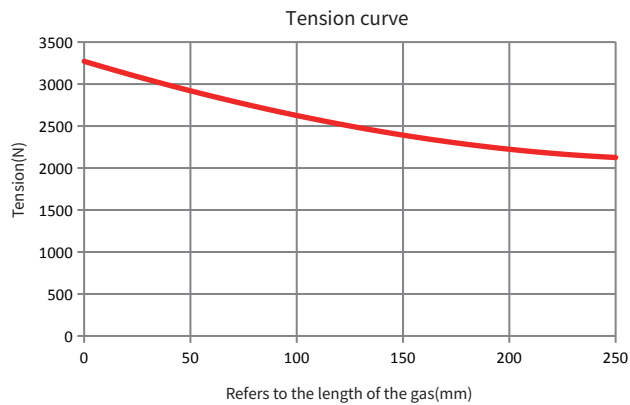

MAIN TECHNICAL PARAMETER

Product model	PGS-200-25
Repeated positioning accuracy (mm)	0.02
Closing force/ Tension force (N)	≥2500/2700
Rated working air pressure (Mpa)	0.6
Single finger stroke (mm)	25
Working air pressure range (MPa)	0.3~0.8
Recommended clamping workpiece weight (Kg)	13

PGS-200-25

SIZE CHART

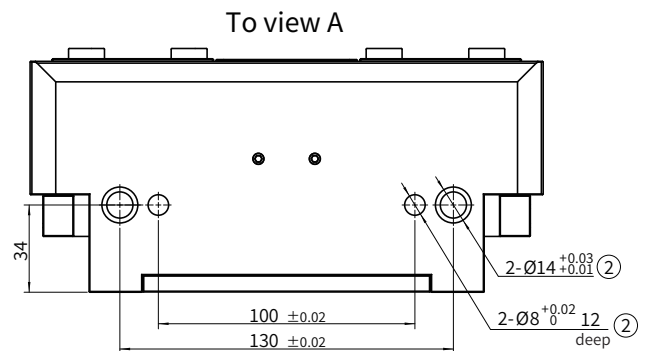
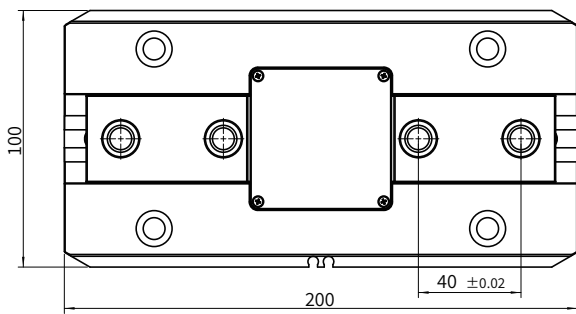
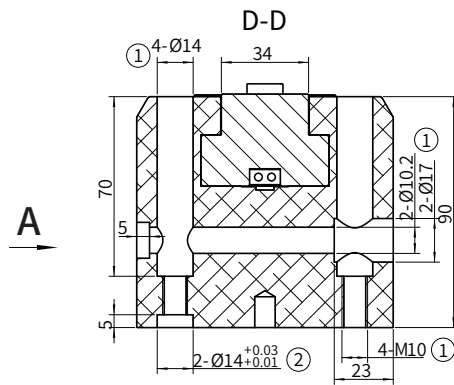
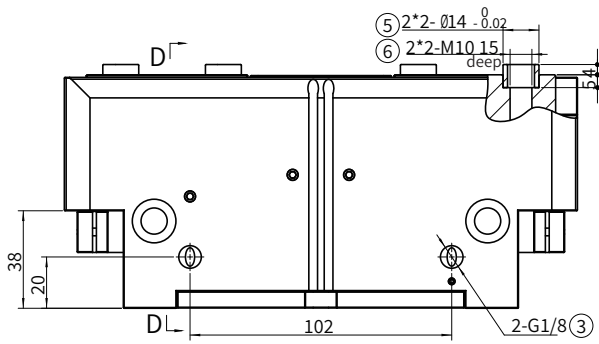
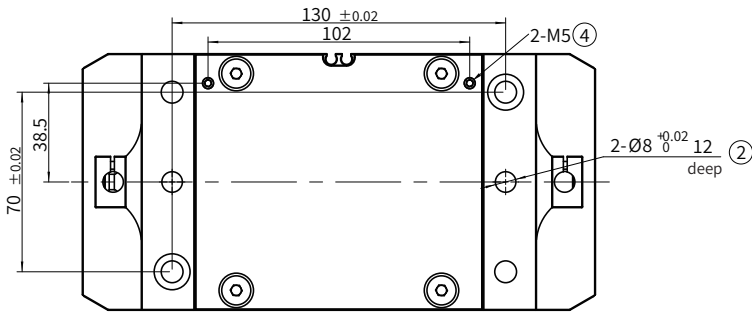

① Gas fingering mounting hole

③ Side air vent

⑤ Soft claw mounting positioning sleeve

② Gas fingering mounting positioning hole

④ Bottom air vent

⑥ Soft claw mounting hole