

THE GRAPH

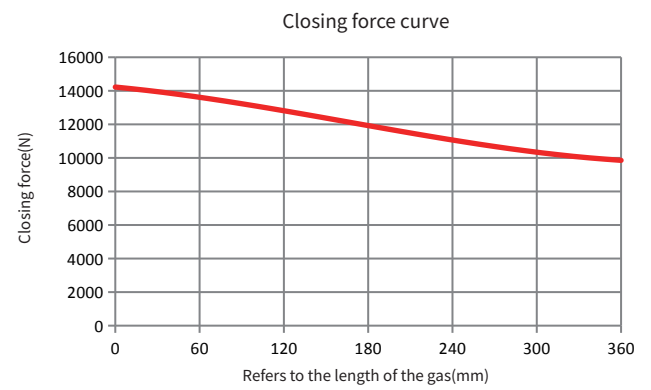
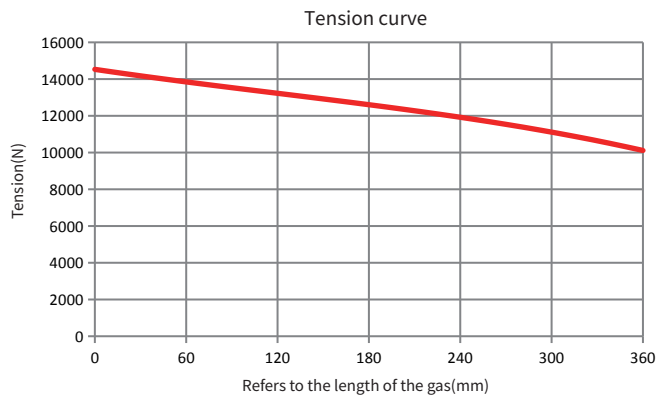

MAIN TECHNICAL PARAMETER

Product model	CGS-300-35
Repeated positioning accuracy (mm)	0.05
Closing force/Tension force (N)	≥12000/12700
Rated working air pressure (Mpa)	0.6
Single finger stroke (mm)	35
Working air pressure range (MPa)	0.3~0.8
Recommended clamping workpiece weight (Kg)	60

CGS-300-35

SIZE CHART

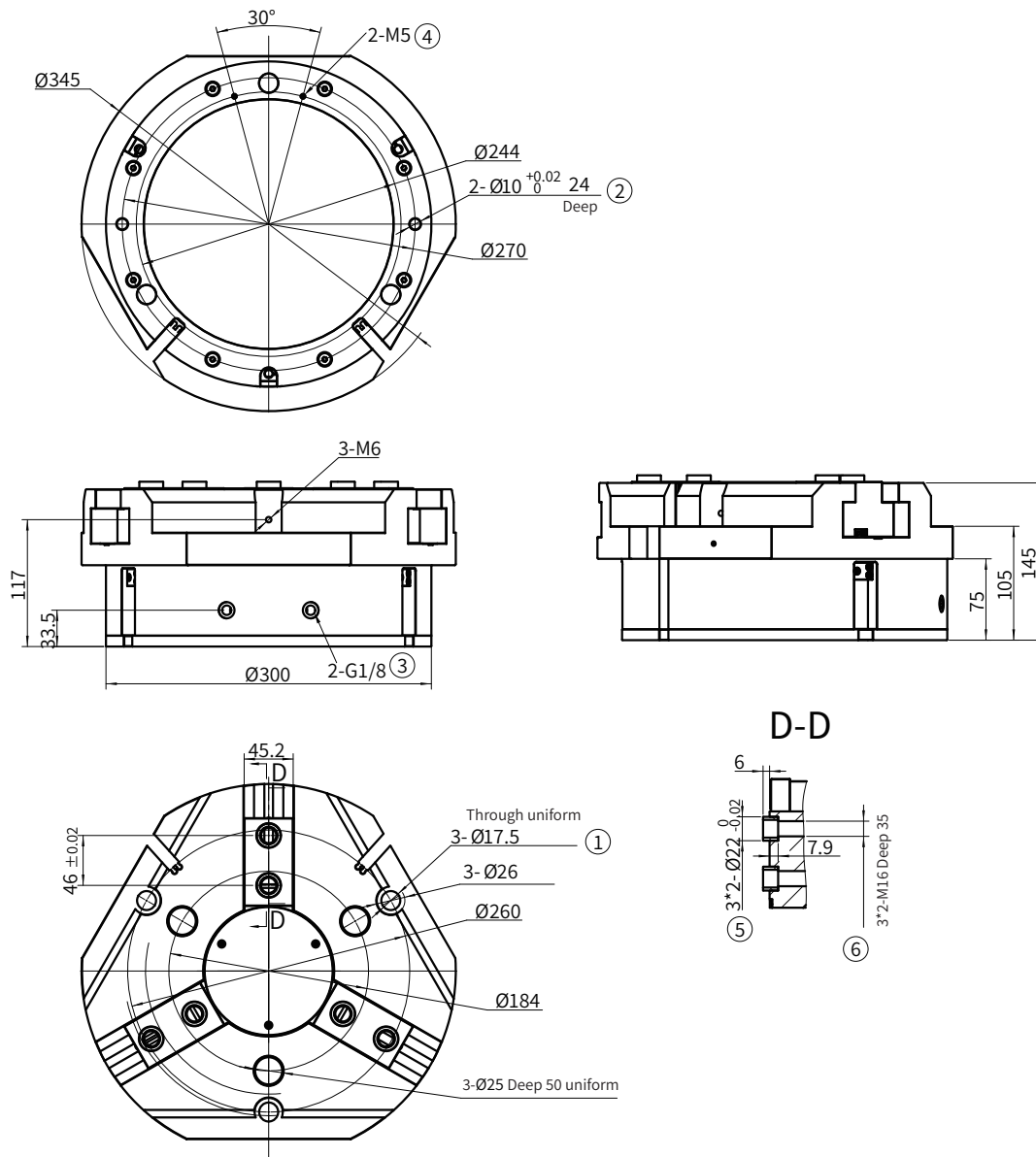

① Gas fingering mounting hole

③ Side air vent

⑤ Soft claw mounting positioning sleeve

② Gas fingering mounting positioning hole

④ Bottom air vent

⑥ Soft claw mounting hole