

THE GRAPH

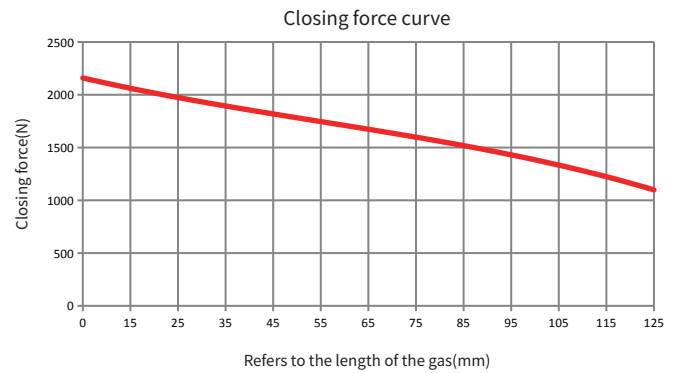
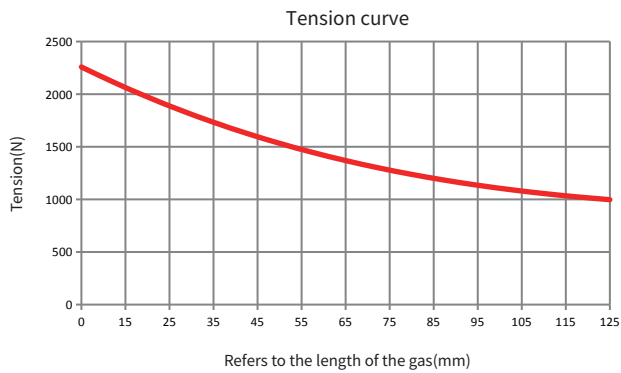

MAIN TECHNICAL PARAMETER

Product model	CGS-100-10
Repeated positioning accuracy (mm)	0.01
Closing force/Tension force (N)	≥1800/1900
Rated working air pressure (Mpa)	0.6
Single finger stroke (mm)	10
Working air pressure range (MPa)	0.3~0.8
Recommended clamping workpiece weight (Kg)	9

CGS-100-10

SIZE CHART

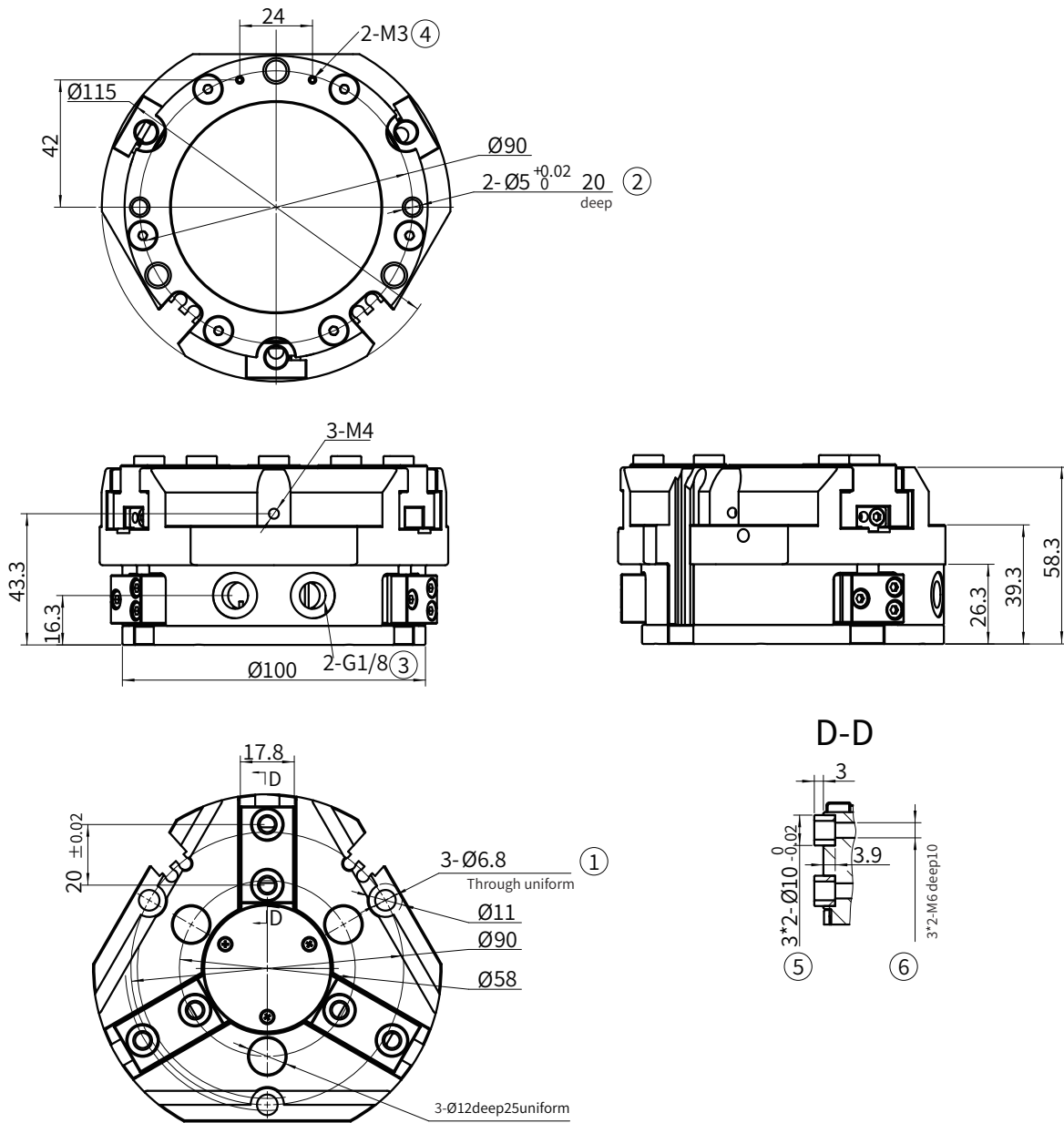

① Gas fingering mounting hole

③ Side air vent

⑤ Soft claw mounting positioning sleeve

② Gas fingering mounting positioning hole

④ Bottom air vent

⑥ Soft claw mounting hole